

(No Model.)

2 Sheets—Sheet 1.

C. E. VAN NORMAN. MILLING MACHINE.

No. 570,723.

Patented Nov. 3, 1896.

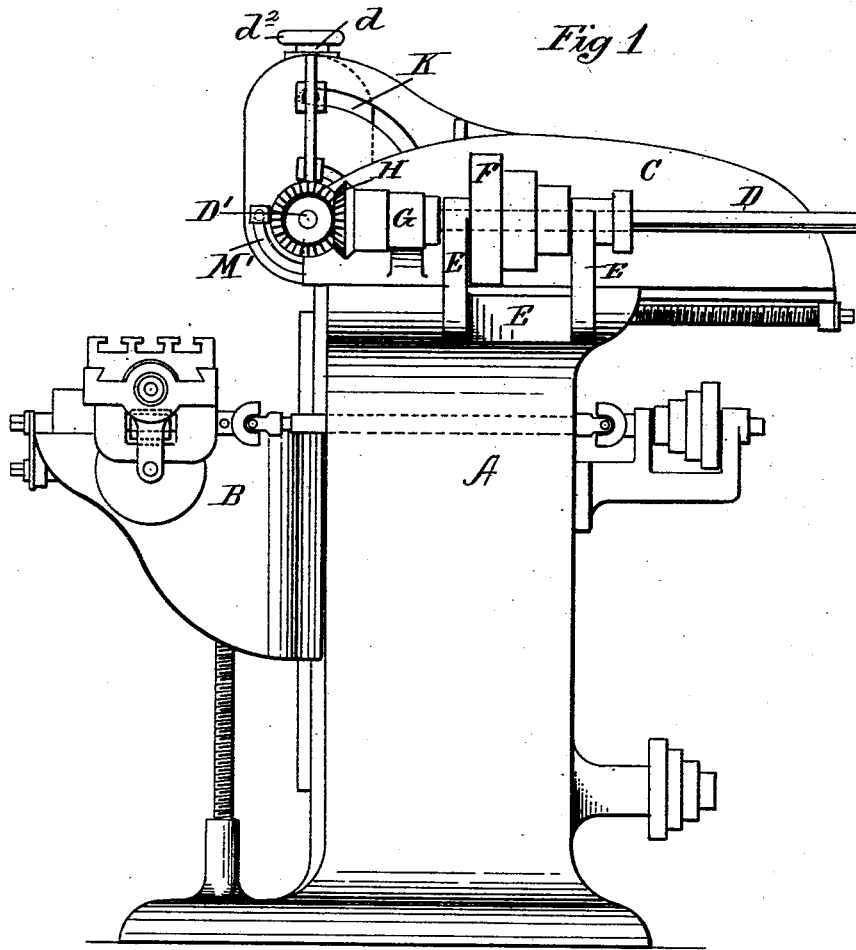

Fig 1

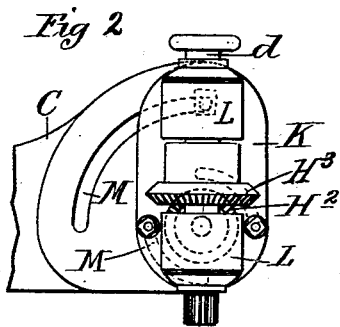

Fig 2

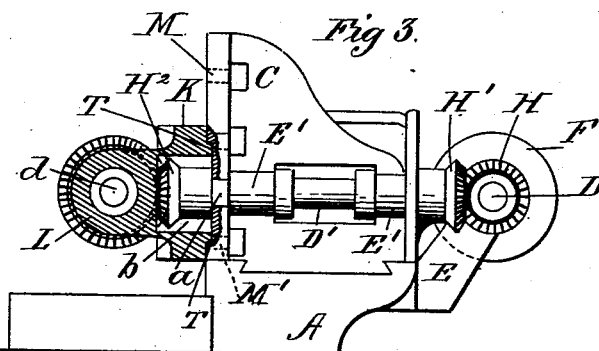

Fig 3

Witnesses

Wm H Chapman
J D Garfield

Inventor.

Charles E Van Norman
By *Chapman & Co*
Attys

C. E. VAN NORMAN.
MILLING MACHINE.

No. 570,723.

Patented Nov. 3, 1896.

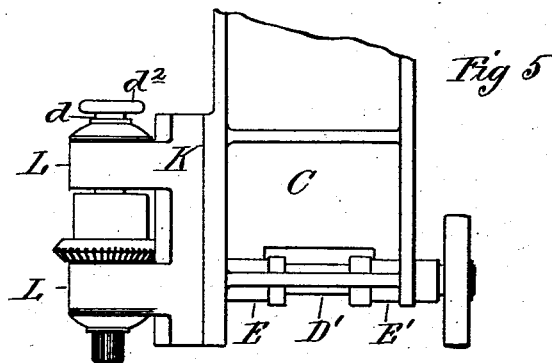
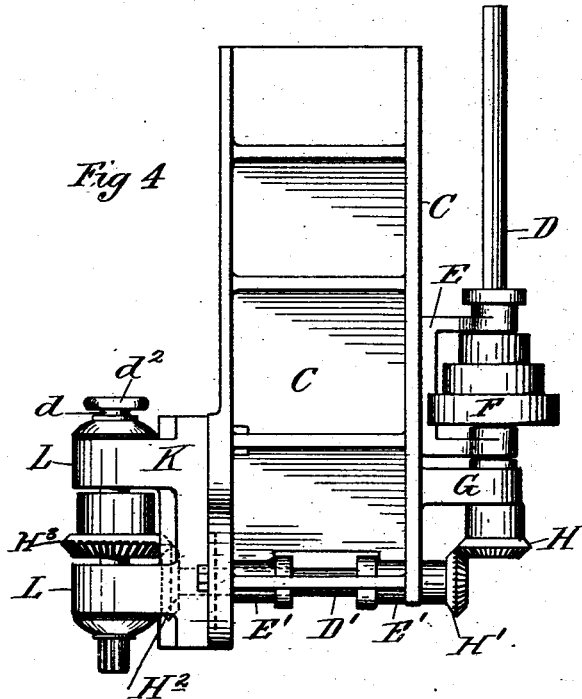

Witnesses
Wm H Chapin
J. M. Gayfield

Inventor.
Charles E Van Norman.
 By *Chapin & Co*
 Attys

UNITED STATES PATENT OFFICE.

CHARLES E. VAN NORMAN, OF SPRINGFIELD, MASSACHUSETTS.

MILLING-MACHINE.

SPECIFICATION forming part of Letters Patent No. 570,723, dated November 3, 1896.

Application filed November 13, 1895. Serial No. 568,783. (No model.)

To all whom it may concern:

Be it known that I, CHARLES E. VAN NORMAN, a citizen of the United States of America, residing at Springfield, in the county of Hampden and State of Massachusetts, have invented new and useful Improvements in Milling-Machines, of which the following is a specification.

This invention relates to milling-machines, and particularly to that class provided with a pivotally-hung tool-carrying head adjustable in a vertical plane to any degree of a circle having for a center the pivot on which said head turns; and the invention consists more particularly in the construction of the driving mechanism for the milling tool or cutter, whereby the latter is positively driven by means of shafts having suitable gear connections with each other, said connections being attached to and adapted to move with the horizontally-sliding head to which the tool-carrying head is attached.

In the drawings forming part of this specification, Figure 1 is a side elevation of a milling-machine embodying my invention and showing the main driving-shaft on the side of the sliding head of the machine and the bevel-gear connection with the shaft across the end of the said head and also showing a portion of the outline of the swiveled cutting-head in dotted lines. Fig. 2 shows a front elevation of the swiveled cutter-head and in dotted lines the bevel-gear engaging with the bevel-gear on the cutter-shaft. Fig. 3 is an end view of the sliding head of the milling-machine and driving connections with the swiveled cutter-head swung to a horizontal position, said head being shown in section. Fig. 4 is a plan view of the sliding head, showing all the driving connections attached thereto and showing the cutter-head in a horizontal position. Fig. 5 shows a modified construction of the driving mechanism.

Referring to the drawings, A represents the base of a milling-machine of the usual construction, having the usual planer-feeding devices for the vertically-adjustable bed B, to which the work is secured, and the usual horizontally-adjustable head C.

On the frame of the machine is cast the

bracket E, having two arms which serve as journal-bearings for the shaft D. On said shaft and between the arms of said bracket E is the driving cone-pulley F, fitting loosely thereon and having a splined connection therewith whereby the said shaft may have a sliding movement through said driving-pulley and be driven thereby.

On the head C of the machine is cast an arm G, having in the end thereof a journal-bearing for the shaft D. On the end of the shaft D, next to the journal-bearing G, is a bevel-gear H, fixed on said shaft, the hub of said gear having a bearing against one side of the arm G, and a collar on the other side of the arm G, also fixed on said shaft, provides means whereby the shaft D is carried by the head C when the latter is moved horizontally, said shaft when said movement takes place sliding freely in the bearings of the bracket E and through the cone-pulley F.

Across the end of the head C, in suitable bearings E', is hung a shaft D', having thereon at one end a bevel-gear H', meshing with gear H on the shaft D, and on the other end thereof another bevel-gear H², both fixed on said shaft D'. One end of said shaft D', with the gear H² thereon, projects through the side of the head C at a, Fig. 3, and into a chamber b, provided in the body of the swiveled cutter-head K. On said cutter-head K two journal-bearings L are cast, in which the shaft d runs. Said shaft is provided with the usual tapered socket for the reception of the similarly-tapered shanks of the various tools used on the machine, a fluted cutter being shown in position in Figs. 2 and 4.

Between the bearings L is the beveled gear H³, fixed on the shaft d and adapted to engage with the bevel-gear H² through an opening made from the front of the head K into said chamber b, said gear H² being, as before stated, fixed on shaft D'. Thus power is directly applied to the cutter through the medium of the gears H H' H² H³ and shafts D and D'.

Referring to Fig. 3, it will be seen that on the back side of the cutter-head K is turned a ring T, projecting somewhat from the surface of the latter, which is designed for a

trunnion on which the said head may turn, and an annular socket to receive said projecting ring is turned in the face of the head C, both ring and socket being concentric with the center of shaft D', carrying gear H², which projects into the chamber b in said cutter-head.

In the side of the head C, to which the swiveled cutter-head K is attached, are the slots M and M', made concentric with center of shaft D', which is the center of rotation of the head K. Bolts f, passing through said slots and head, serve to secure the latter in any position to which it is desirable to adjust it.

It will be seen that as the center of gear H² is coincident with the center of the trunnion T, on which the head K turns, that in whatsoever position said head may be turned to the gears H² and H³ are always connected, and consequently the same positive driving power is applied to the shaft d, carrying the cutter or milling-tool, whether said cutter-head occupies a vertical or horizontal position or any point of the circle therebetween, the gear H³ always revolving about the periphery of the gear H² and receiving power therefrom. The cutting-tool on the end of shaft d is capable of adjustment in line with said shaft by means of hand-wheel d² in the manner usually employed in such constructions, as, for example, the adjustment of the spindles in a lathe.

The advantages of this construction and application to milling-machines of the class to which this invention belongs (of a positive driving mechanism for the milling-tool) are obvious, the tool-shaft in such machines having been heretofore commonly driven by a belt, which with each change of position of the swivel-head relative to the frame necessitated the loosening or tightening of the driving-belt by means of an idler, entailing thereby loss of time and a consequent diminution of efficiency, and besides not affording the same powerful means of driving the cutting-tool as is obtained by the use of this invention.

It is obvious that where a machine is to be always employed on any class of work which would not necessitate a great degree of movement of the horizontally-sliding head C the gear H' could be replaced by a driving-pulley, which would be belted directly to a counter-shaft, and all of the parts carried by the shaft D could be dispensed with, as well as shaft D also, without departing from this invention, the most important feature of which is the construction of swivel-head having the driving-gear for the tool-shaft therein, which gear is adapted to rotate about a central point which is coincident with the center of the shaft from which power is transmitted to said gear in the swiveled head.

Having thus described my invention, what I claim, and desire to secure by Letters Patent, is—

1. In a milling-machine, a main head horizontally adjustable on the machine, an auxiliary head attached for rotatable adjustment to the side of said main head, a tool-carrying spindle supported to rotate in said auxiliary head, a shaft supported in said main head at right angles to said spindle, gear connections between said spindle and shaft, combined with a driving-shaft moving horizontally with said main head, and a driving-pulley on said shaft supported on the base of the machine, substantially as set forth.

2. In a milling-machine, a main head horizontally adjustable on the machine, an auxiliary head attached for rotatable adjustment to the side of said main head, a tool-carrying spindle supported to rotate in said auxiliary head, a shaft supported in said main head at right angles to said spindle, gear connections between said spindle and shaft, combined with a second driving-shaft D, supported in bearings fixed to the base A, of the machine, having geared connection with the shaft in said main head, a driving-pulley on said shaft D, having a spline-and-groove connection therewith, and an arm on said main head engaging said driving-shaft D, whereby the latter and said main head have coinciding horizontal movements, substantially as set forth.

3. In a milling-machine, a main head horizontally adjustable on the machine, an auxiliary head attached for rotatable adjustment to the side of the main head in a plane at right angles to the movement of the work-holding table and parallel with the movement of the main head to which it is attached, a tool-carrying spindle supported to rotate in said auxiliary head, a shaft supported in said main head at right angles to said spindle, and extending through the side wall on which the auxiliary head is pivoted, gear connections between said shaft and spindle combined with driving mechanism for rotating said shaft, substantially as described.

4. A main horizontally-adjustable head provided with a vertical wall upon one side, and suitable bearings in or upon its front end for the driving-shaft for the tool-spindle, combined with a rotatable head pivoted upon the said vertical wall, means for securing the rotatable head in place, the driving-shaft for the tool-spindle journaled upon the front end of the main head and having one end extend through both the vertical wall and the rotatable head and provided with a gear, and a tool-carrying spindle mounted upon the rotatable head and provided with a gear to engage with the one on the end of the driving-shaft, substantially as shown.

5. In a milling-machine, a base, a table for the work vertically adjustable thereon, and a horizontally-adjustable main head placed upon the top of the base, and provided with a slotted vertical wall, upon one side, and suitable bearings upon its front end for the driving-shaft for the spindle, combined with

driving-shaft D', having one of its ends project through both the side wall and the rotatable head and provided with a gear; the rotatable head pivoted on the outer side of the
5 vertical wall and provided with means to hold it in position; and the spindle provided with a gear to engage with the one on the end of

the driving-shaft; the pivot of the rotatable head being formed around the end of the driving-shaft, substantially as described.

CHARLES E. VAN NORMAN.

Witnesses:

H. A. CHAPIN,
WM. H. CHAPIN.